

ISOMETRIC VIEW

MARK	PC.DET.	QTY	STEEL SHAPE	DESCRIPTION / 1ST DIMENSION	2ND DIM	LENGTH	REMARKS	WT	SF
VI-4x10-A		1		VENT INSERT 4x10				0.72	0.00
	pa	1	PL	0.25	4	10		0.72	0.66

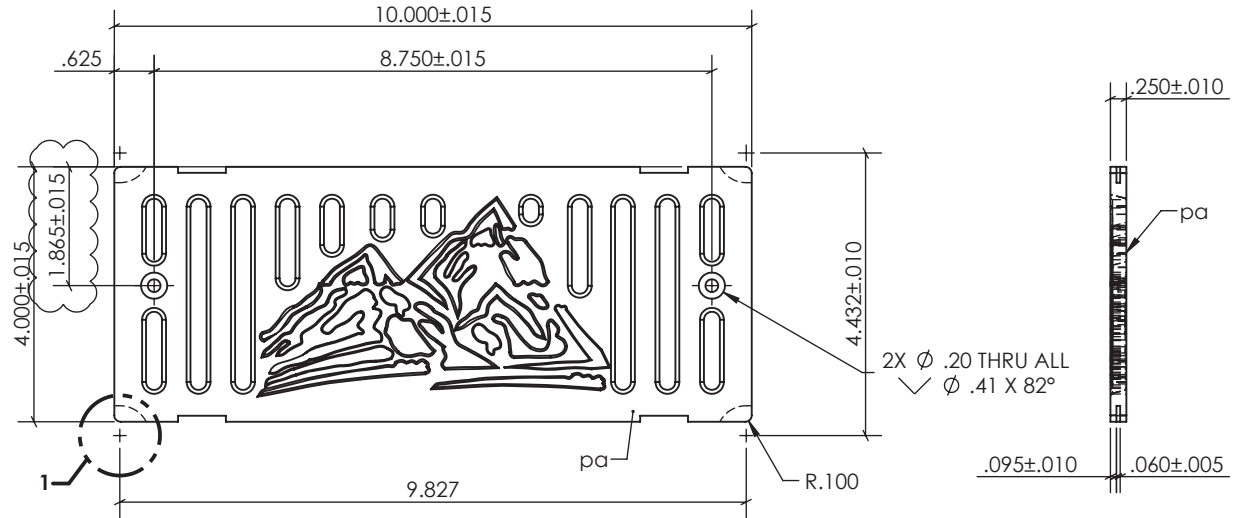

DETAIL: VI-4x10-A

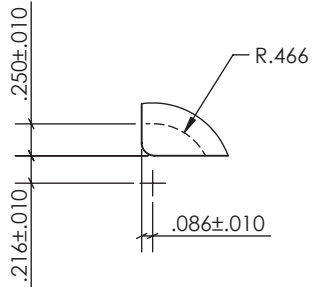

DETAIL

SCALE:1:1

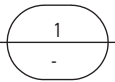

DESCRIPTION: DETAIL 4x10 VENT INSERT AVALANCHE		
DRAWN BY: Don Benkowski	DATE: 07/08/20	SCALE: 6"=1'-0"
CHECKED BY:	DATE:	JOB NO.:
DWG NO: VI-4x10-A	SHEET NO.: 1 OF 1	REV.: 1

NO.	DATE	REVISION	BY
0	07/08/20	ISSUED FOR FABRICATION	db
1	7/22/2020	REVISED DIMENSION	db

FABRICATION TOLERANCES: (UNLESS NOTED)

±.0005 ±.0005 ±.0005 ±.0005
 ±.0005 ±.0005 ±.0005 ±.0005